

Tubular handles

Item description/product images



Description

Material:

Legs black glass-bead reinforced thermoplastic.
Grip aluminium EN AW-6060.

Version:

Form A
Grip, ground and natural colour anodised.
Form B
Grip with serrated plastic sheath.

Note:

The legs have 4 webs in the hole for the grip tube. When pushing the tube in these are trimmed off and produce a precise seating. Black electro zinc-plated fastening screws, suitable washers and nuts are supplied.

Assembly:

From the front.

Drawings

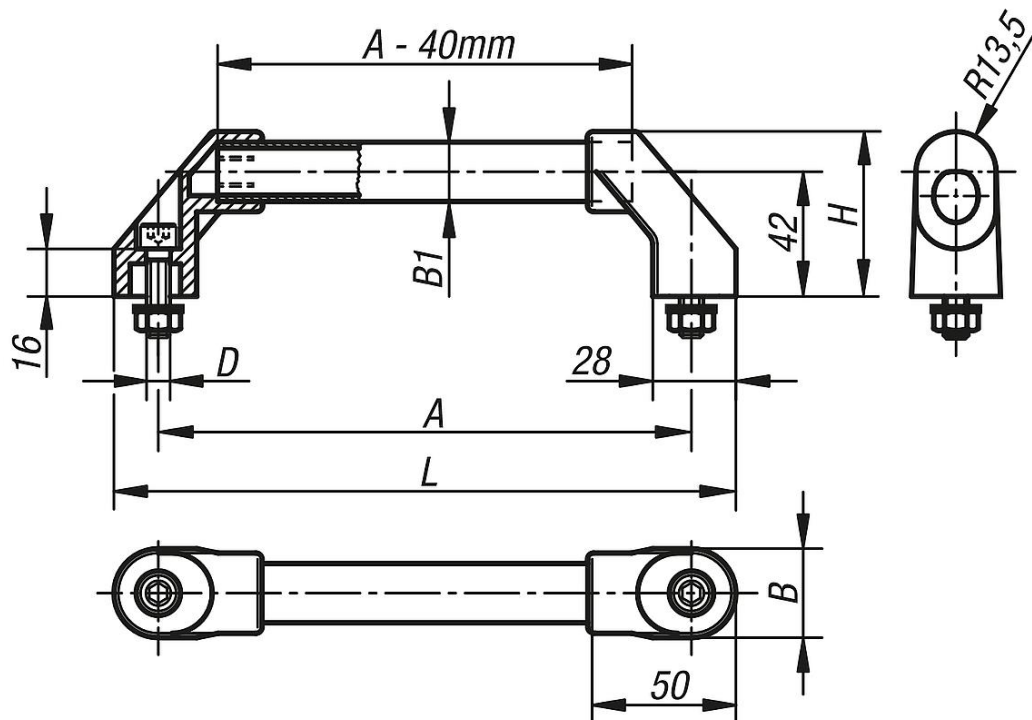

Overview of items

Tubular handles

Order No.	Surface finish body	A	B	B1	D	H	L	Load capacity N
K0221.1801	ground and anodized	180	30	20X2	M8X30	55,5	210	1000

Tubular handles

Overview of items

Order No.	Surface finish body	A	B	B1	D	H	L	Load capacity N
K0221.2001	ground and anodized	200	30	20X2	M8X30	55,5	230	1000
K0221.2501	ground and anodized	250	30	20X2	M8X30	55,5	280	1000
K0221.3001	ground and anodized	300	30	20X2	M8X30	55,5	330	1000
K0221.3501	ground and anodized	350	30	20X2	M8X30	55,5	380	1000
K0221.4001	ground and anodized	400	30	20X2	M8X30	55,5	430	1000
K0221.5001	ground and anodized	500	30	20X2	M8X30	55,5	530	1000
K0221.6001	ground and anodized	600	30	20X2	M8X30	55,5	630	1000
K0221.1802	serrated plastic sleeve	180	30	20X2	M8X30	55,5	210	1000
K0221.2002	serrated plastic sleeve	200	30	20X2	M8X30	55,5	230	1000
K0221.2502	serrated plastic sleeve	250	30	20X2	M8X30	55,5	280	1000
K0221.3002	serrated plastic sleeve	300	30	20X2	M8X30	55,5	330	1000
K0221.3502	serrated plastic sleeve	350	30	20X2	M8X30	55,5	380	1000
K0221.4002	serrated plastic sleeve	400	30	20X2	M8X30	55,5	430	1000
K0221.5002	serrated plastic sleeve	500	30	20X2	M8X30	55,5	530	1000
K0221.6002	serrated plastic sleeve	600	30	20X2	M8X30	55,5	630	1000