

Indexing plungers without collar

Item description/product images



Description

Material:

Steel version:

Indexing pin hardened:

Sleeve 1.0403 weldable.

Indexing pin grade 5.8.

Stainless steel version:

Indexing pin hardened:

Sleeve 1.4301 weldable.

Indexing pin 1.4034.

Indexing pin not hardened:

Sleeve 1.4301 weldable.

Indexing pin 1.4305.

Mushroom knob black grey thermoplastic.

Version:

Steel version:

Indexing pin hardened, ground, black oxidised.

Stainless steel version:

Indexing pin hardened, ground and bright.

Indexing pin not hardened, ground and bright.

Note:

Indexing plungers are used to prevent any change in locking position due to lateral forces. A new locking position can only be set after the pin has been manually disengaged.

Form M is recommended for applications in where the indexing plungers should remain disengaged over extended periods and the pin prevented from springing back.

To weld the indexing plungers we recommend inert gas-shielded welding with TIG welding equipment.

On request:

Special versions.

Indexing plungers without collar

Drawings

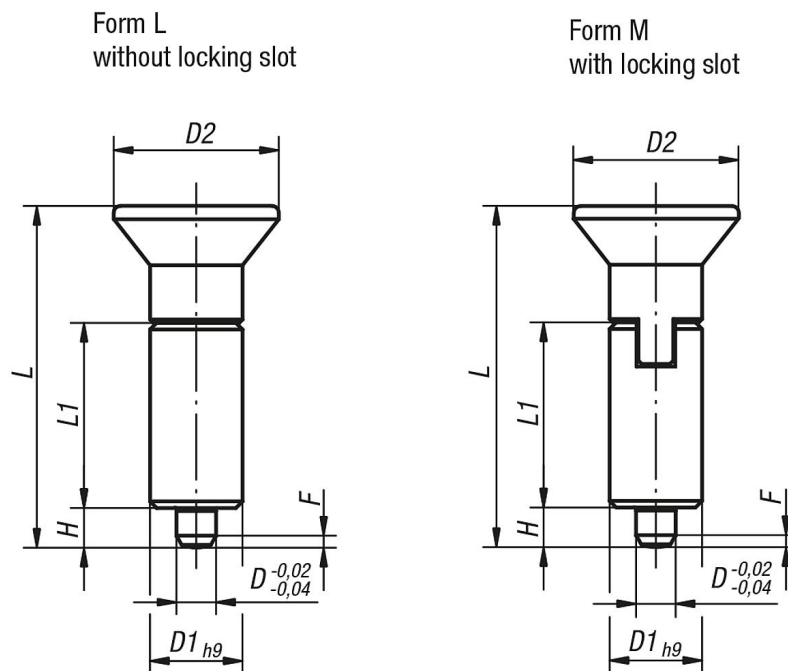

Overview of items

Indexing plungers without collar, steel, indexing pin hardened

Order No. Form L	Order No. Form M	D	D1	D2	L	L1	H	Fx30°	Spring force initial pressure F1 approx. N	Spring force final pressure F2 approx. N
K0346.1004	K0346.2004	4	10	18	38,5	21	4	1	6	12
K0346.1105	K0346.2105	5	12	21	43,5	24	5	1,3	5	12
K0346.1206	K0346.2206	6	14	25	51,7	28	6	1,8	6	14
K0346.1308	K0346.2308	8	18	33	68	36	8	2,3	15	35
K0346.1410	K0346.2410	10	22	33	74	40	10	2,8	15	34

Indexing plungers without collar, stainless steel, indexing pin hardened

Order No. Form L	Order No. Form M	D	D1	D2	L	L1	H	Fx30°	Spring force initial pressure F1 approx. N	Spring force final pressure F2 approx. N
K0346.01004	K0346.02004	4	10	18	38,5	21	4	1	6	12
K0346.01105	K0346.02105	5	12	21	43,5	24	5	1,3	5	12
K0346.01206	K0346.02206	6	14	25	51,7	28	6	1,8	6	14
K0346.01308	K0346.02308	8	18	33	68	36	8	2,3	15	35
K0346.01410	K0346.02410	10	22	33	74	40	10	2,8	15	34

Indexing plungers without collar, stainless steel, indexing pin not hardened

Order No. Form L	Order No. Form M	D	D1	D2	L	L1	H	Fx30°	Spring force initial pressure F1 approx. N	Spring force final pressure F2 approx. N
K0346.11004	K0346.12004	4	10	18	38,5	21	4	1	6	12
K0346.11105	K0346.12105	5	12	21	43,5	24	5	1,3	5	12
K0346.11206	K0346.12206	6	14	25	51,7	28	6	1,8	6	14
K0346.11308	K0346.12308	8	18	33	68	36	8	2,3	15	35
K0346.11410	K0346.12410	10	22	33	74	40	10	2,8	15	34