

Deep pot round magnets with machinable magnetic face NdFeB

Item description/product images



Description

Material:

Housing brass.

Magnetic core NdFeB (neodymium).

Note:

Smooth design, shielded system. Under no circumstances may Neodym magnets be pressed directly into iron, loss of attractive force due to magnetic short circuits occurs. Diameter "D" ground to an h6 tolerance.

These magnets can be shortened by the dimensions "H1" and "H2".

Temperature range:

max. 150°C.

Assembly:

The magnets can be mounted by press-fit, screwing-in or gluing.

Drawing reference:

1) magnetic face

Deep pot round magnets with machinable magnetic face NdFeB

Drawings

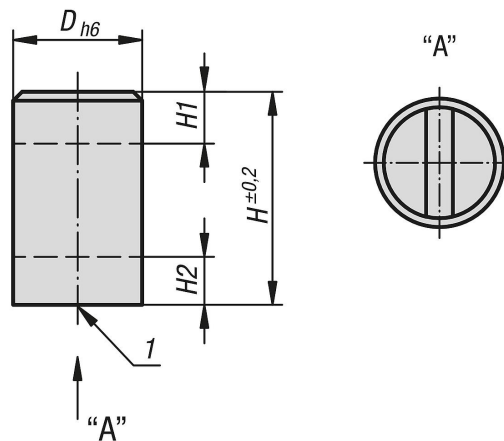

Overview of items

Deep pot NdFeB round magnets with machinable magnetic face

Order No.	D	H	H1	H2	Magnetic force N	Magnetic force at H2 max. N	Gap to iron wall mm
K1403.06	6	20	10	3	9	12	1,5
K1403.08	8	20	10	3	22	29	1,5
K1403.10	10	20	8	5	27	38	2
K1403.13	13	20	6	5	49	66	2,5
K1403.16	16	20	2	6	94	108	3
K1403.20	20	25	5	7	173	235	4
K1403.25	25	35	7	8	292	380	5
K1403.32	32	40	4,5	10	529	640	6