

Indexing plungers short version

Item description/product images

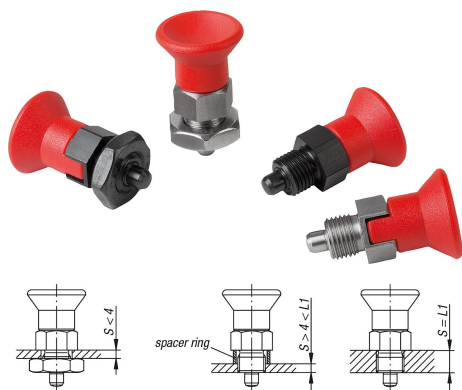

Description

Material:

Steel version:
Indexing pin hardened:
steel grade 5.8.

Stainless steel version,
Indexing pin not hardened
Threaded sleeve and indexing pin 1.4305.

Mushroom knob red thermoplastic

Version:

Steel version:
Indexing pin hardened, ground, black oxidised.

Stainless steel version:
Indexing pin not hardened, ground, bright.

Note:

Indexing plungers are used to prevent any change in position due to lateral forces. A new locking position can only be set after the pin has been manually disengaged. Form C or D is recommended for applications in which the pin is disengaged over extended periods and should be prevented from springing back.

On request:

Special versions.

Accessory:

Spacer rings K0665

Drawings

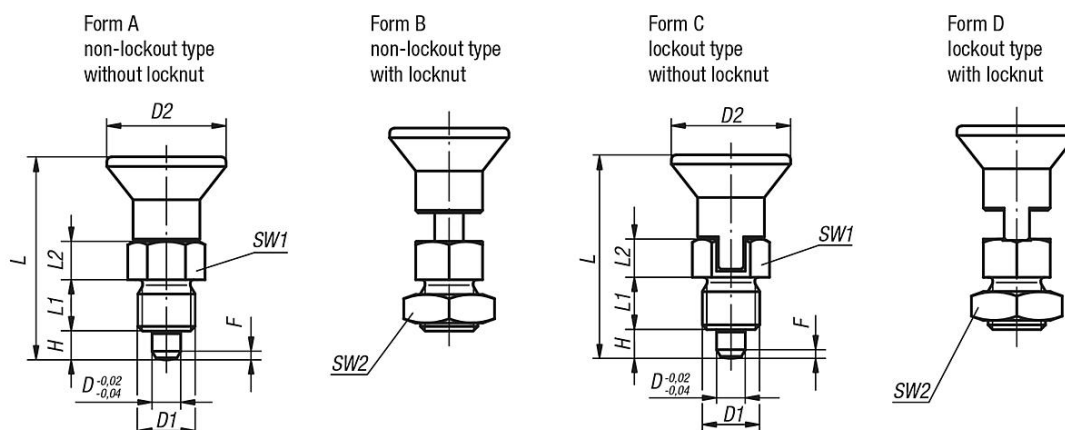

Overview of items

Indexing plungers, short version, steel, indexing pin hardened

Indexing plungers short version

Overview of items

Order No. Form A	Order No. Form B	Order No. Form C	Order No. Form D	D	D1	D2	L	L1	L2	H	SW1	SW2	Fx30°	Spring force initial pressure F1 approx. N	Spring force final pressure F2 approx. N
K0631.590384	K0631.690384	K0631.790384	K0631.890384	3	M6x0,75	14	25,5	6	5	3,5	8	-/10-/10	0,8	4	10
K0631.500484	K0631.600484	K0631.700484	K0631.800484	4	M8x1	18	29,5	6	6	4	10	-/13-/13	1	4	12
K0631.510584	K0631.610584	K0631.710584	K0631.810584	5	M10x1	21	34,5	8	7	5	13	-/17-/17	1,3	5	12
K0631.520684	K0631.620684	K0631.720684	K0631.820684	6	M12x1,5	25	41,7	10	8	6	14	-/19-/19	1,8	6	14
K0631.530884	K0631.630884	K0631.730884	K0631.830884	8	M16x1,5	33	54	12	10	8	19	-/24-/24	2,3	14	28
K0631.541084	K0631.641084	K0631.741084	K0631.841084	10	M20x1,5	33	61	15	12	10	22	-/30-/30	2,8	15	32

Indexing plungers, short version, stainless steel, indexing pin not hardened

Order No. Form A	Order No. Form B	Order No. Form C	Order No. Form D	D	D1	D2	L	L1	L2	H	SW1	SW2	Fx30°	Spring force initial pressure F1 approx. N	Spring force final pressure F2 approx. N
K0631.1590384	K0631.1690384	K0631.1790384	K0631.1890384	3	M6x0,75	14	25,5	6	5	3,5	8	-/10-/10	0,8	4	10
K0631.1500484	K0631.1600484	K0631.1700484	K0631.1800484	4	M8x1	18	29,5	6	6	4	10	-/13-/13	1	4	12
K0631.1510584	K0631.1610584	K0631.1710584	K0631.1810584	5	M10x1	21	34,5	8	7	5	13	-/17-/17	1,3	5	12
K0631.1520684	K0631.1620684	K0631.1720684	K0631.1820684	6	M12x1,5	25	41,7	10	8	6	14	-/19-/19	1,8	6	14
K0631.1530884	K0631.1630884	K0631.1730884	K0631.1830884	8	M16x1,5	33	54	12	10	8	19	-/24-/24	2,3	14	28
K0631.1541084	K0631.1641084	K0631.1741084	K0631.1841084	10	M20x1,5	33	61	15	12	10	22	-/30-/30	2,8	15	32